

CARGA DE BATERIA•BATTERY RECHARGE•CHARGE DE LA BATTERIE•AUFLADUNG DER BATTERIE•DE ACCU-OPLADER•CARGA DE BATERIA•CARICA DELLA BATTERIA



•REALIZAR POR UN ADULTO
•THIS SHOULD BE DONE BY AN ADULT
•A RÉALISER PAR UN ADULTE
•DIES IST VON EINEM ERWACHSENEN AUSZUFÜHREN
•UIT TE VOEREN DOOR EEN VOLWASSENE
•A REALIZAR POR UM ADULTO
•DEVE REALIZZARLO UN ADULTO



•POR FAVOR, SIGA EstrictAMENTE LA SECUENCIA DE RECARGA DE LA BATERIA.
•PLEASE FOLLOW CAREFULLY THE INSTRUCTIONS FOR RE-CHARGING THE BATTERY ; FAILURE TO COMPLY WITH THIS PROCEDURE WILL DAMAGE THE BATTERY. THE BATTERY IS NOT COVERED UNDER THE WARRANTY.
•VEUILLEZ SUIVRE À LA LETTRE SCRUPULEUSEMENT LA PROCÉDURE DE RECHARGEMENT DE LA BATTERIE.
•BEI DER AUFLADUNG DER BATTERIE FOLGEN SIE BITTE GENAUESTENS DER REIHENFOLGE.
•VOLG A.U.B. DE OPLAADVOLGORDE VAN DE BATTERIJ STRIKT OP
•POR FAVOR, SIGA ATENTAMENTE A SECUENCIA DE RECARGA DA BATERIA
•PER FAVORE SEGUA ATTENTAMENTE LA SEQUENZA DELLA RICARICA DELLA BATTERIA

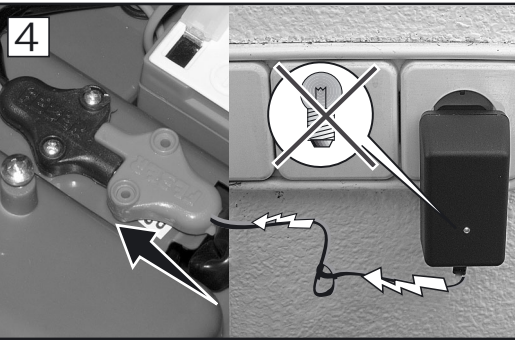
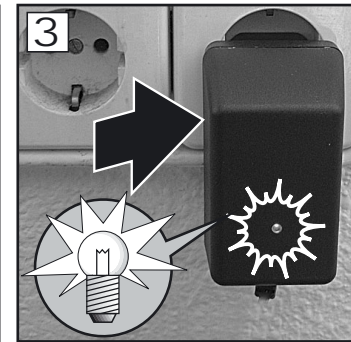
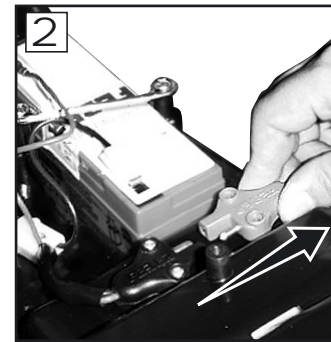
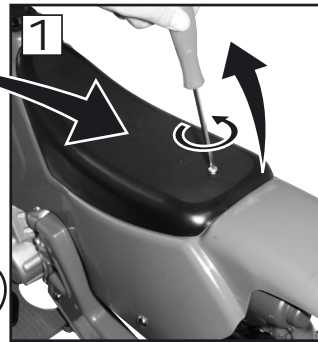
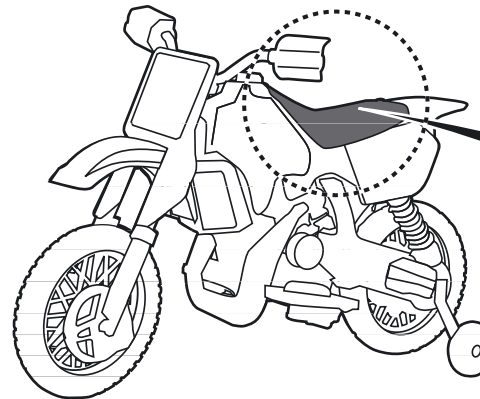

•EL TIEMPO DE DURACION DE LA RECARGA ES (HORAS):
•RECHARGING TIME IS (HOURS):
•LA DURÉE DE LA RECHARGE EST D'ENVIRON (HEURES):
•DIE LADEZEIT IST VON (STUNDEN):
•OPLAAD-TIJD (UUR):
•O TEMPO DE DURAÇÃO DA RECARGA É (HORAS):
•IL TEMPO DI DURATA DELLA RICARICA È (ORE):

14-17 (APPROX.)



CUANDO LA LUZ PILOTO SE VUELVA A ENCENDER, LA BATERIA ESTARÁ CARGADA.
ONCE THE BATTERY HAS BEEN CHARGED, THE CHARGER PILOT WILL TURN ON.
QUAND LA BATTERIE SERA ENTIEREMENT CHARGÉE, LA LUMIÈRE SE RALLUMERA AUTOMATIQUEMENT.
WENN DAS SIGNALLICHT WIEDER AUFLEUCHTET IST DIE BATTERIE AUFGELADEN.
WANNEER HET LICHTJE TERUG GAAT BRANDEN, IS DE BATTERIJ VOLLEDIG OPGELADEN.
QUANDO A LUZ PILOTO SE VOLTAR A ACENDER, A BATERIA ESTARÁ CARGADA.
QUANDO LA SPIA SI ACCENDE DI NUOVO, LA BATTERIA SARÀ CARICA.

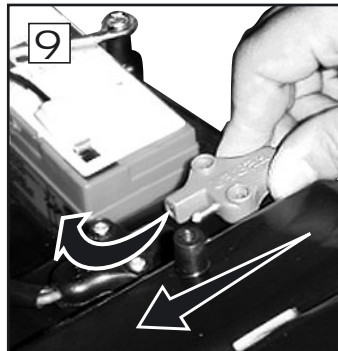
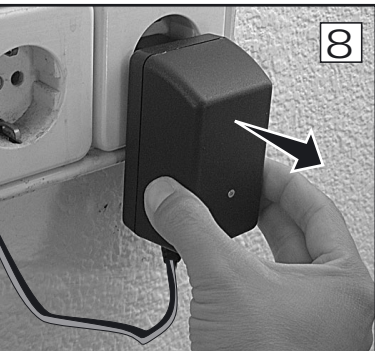
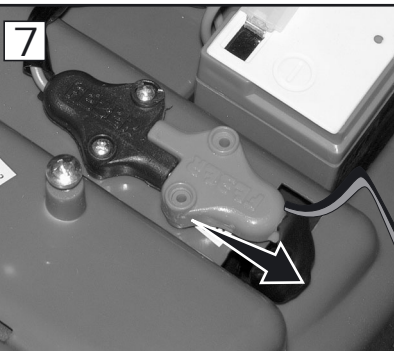
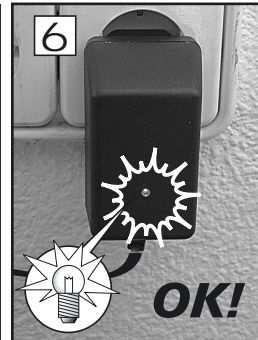

SUSTITUCIÓN DE LA BATERÍA USADA•REMOVE EXHAUSTED BATTERIES FROM THE TOY•CHANGEMENT DE LA BATTERIE USAGÉE DU JOUET•DIE ERSETZUNG DER GEBRAUCHTEN BATTERIE•ERVANGING VAN DE GEBRUIKTE BATTERIJ•SUBSTITUIÇÃO DA BATERIA USADA•SOSTITUZIONE DELLA BATTERIA USATA



•REALIZAR POR UN ADULTO
•THIS SHOULD BE DONE BY AN ADULT
•A RÉALISER PAR UN ADULTE
•DIES IST VON EINEM ERWACHSENEN AUSZUFÜHREN
•UIT TE VOEREN DOOR EEN VOLWASSENE
•A REALIZAR POR UM ADULTO
•DEVE REALIZZARLO UN ADULTO



•¡ADVERTENCIA! NO CORTOCIRCUITAR LA BATERIA.
•WARNING! NOT TO SHORT-CIRCUIT SUPPLY TERMINALS
•ATTENTION! NE PAS COURT-CIRCUITER LES BORNES DE L'ACCUMULATEUR
•WARNUNG! BATTERIEN NICHT KURZSCHLIEßEN.
•WAARSCHUWING! DE BATTERIJ NIET KORTSLUITEN.
•AVISO! NÃO PROVOCAR CURTO-CIRCUITO NA BATERIA.
•AVVERTENZA! NON FAR FARE CORTO CIRCUITO ALLA BATTERIA.

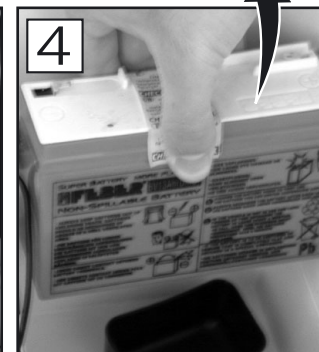
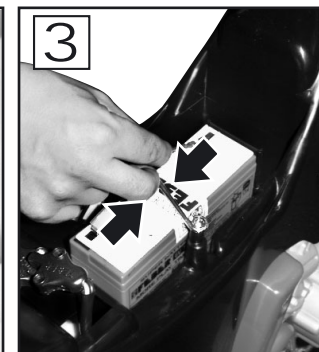
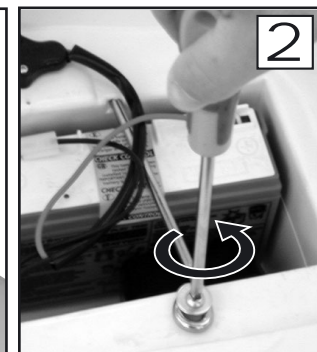
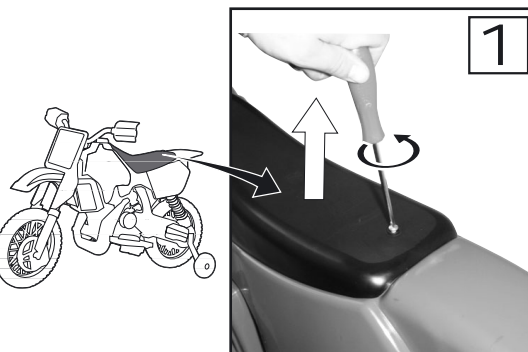

•¡ADVERTENCIA! NO CONVIENE A NIÑOS MENORES DE 36 MESES. POR CONTENER PIEZAS PEQUEÑAS QUE PUEDEN SER INGERIDAS O INHALADAS.
•WARNING! NOT SUITABLE FOR CHILDREN UNDER 36 MONTHS. SINCE IT CONTAINS SMALL PIECES THAT CAN BE INGESTED OR INHALED. CONTAINS POTENTIALLY HAZARDOUS SHARP EDGES OR SHARP POINTS, BEFORE THE ASSEMBLING. THIS TOY IS TO BE ASSEMBLED BY AN ADULT.
•AVERTISSEMENT! NE CONVIENT PAS AUX ENFANTS DE MOINS DE 36 MOIS. CAR IL CONTIENT DES PETITES PIÈCES POUVANT ÊTRE AVALÉES OU INHALÉES.
•WARNUNG! NICHT GEEIGNET FÜR KINDER UNTER 36 MONATEN.DIE KLEINEN TEILE KÖNNEN IN MUND ODER NASE EINGEFÜHRT WERDEN.
•WAARSCHUWING! GEZIEN DE TECHNISCHE EIGENSCHAPPEN VAN HET SPEELTUIG IS HET NIET AAN TE RIJDEN VOOR PEUTERS ONDER DE 36 MAANDEN.
•AVISO! NÃO É ACONSELHÁVEL PARA CRIANÇAS MENORES DE 36 MESES, VISTO CONTER PEÇAS PEQUENAS QUE PODEM SER INGERIDAS OU INALADAS.
•AVVERTENZA! NON È ADEGUATO PER BAMBINI MINORI DI 36 MESI PERCHÉ CONTIENE COMPONENTI DI PICCOLO TAGLIO CHE POSSONO ESSERE INGERITI O INALATI.



AÑOS YEARS ANS JAHRE JAAR ANOS ANI

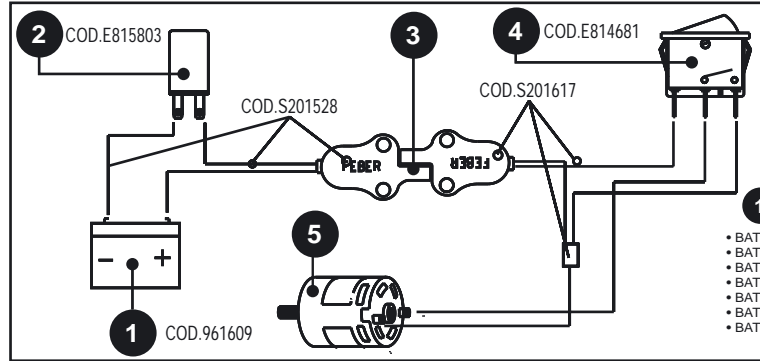

TIEMPO DE JUEGO:
RUNNING TIME:
DURÉE DE FONCTIONNEMENT:
SPIELZEIT:
RIJTTIJD:
TEMPO DE JOGO:
TEMPO DI GIOCO:



1:30' (APPROX.)

PESO MÁXIMO RECOMENDADO:
RECOMMENDED MAXIMUM WEIGHT:
POIDS MAX. RECOMMANDÉ:
EMPFOHLENES GEWICHT:
MAXIMUM AANBEVOLEN GEWICHT:
PESO MÁXIMO RECOMENDADO:
PESO MASSIMO RACCOMANDATO:



50kg

CONTENIDO•CONTENTS•CONTENU•INHALT•INHOUD•CONTEÚDO•CONTENUTO

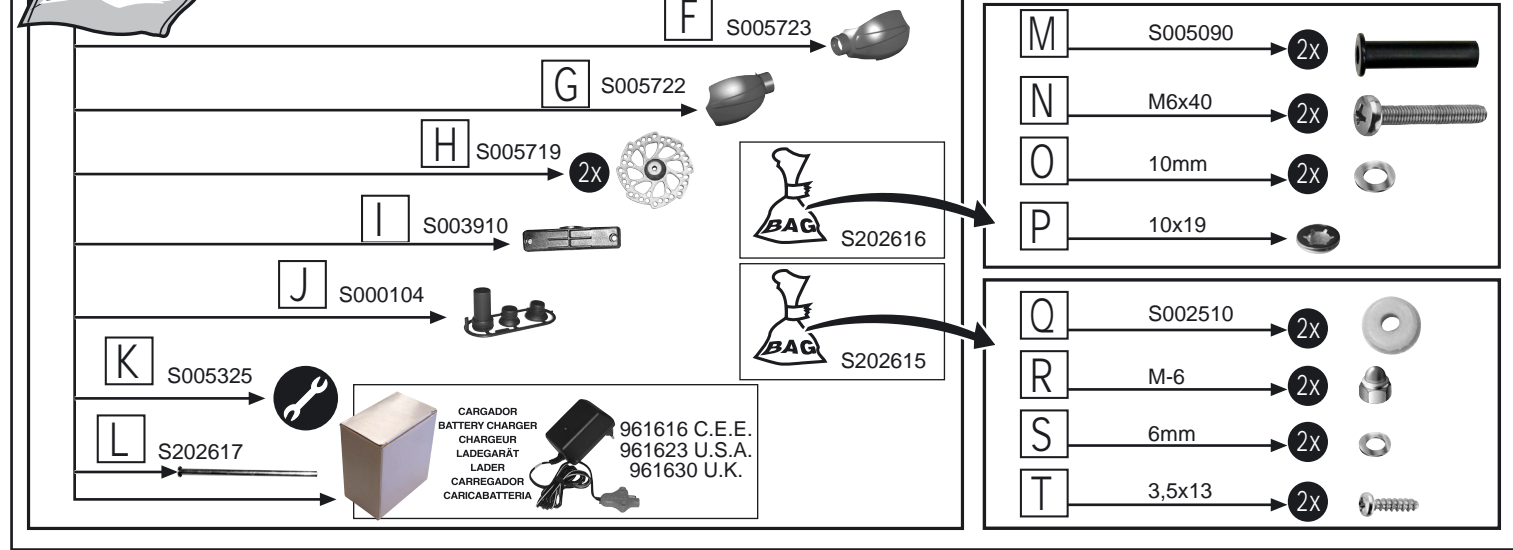
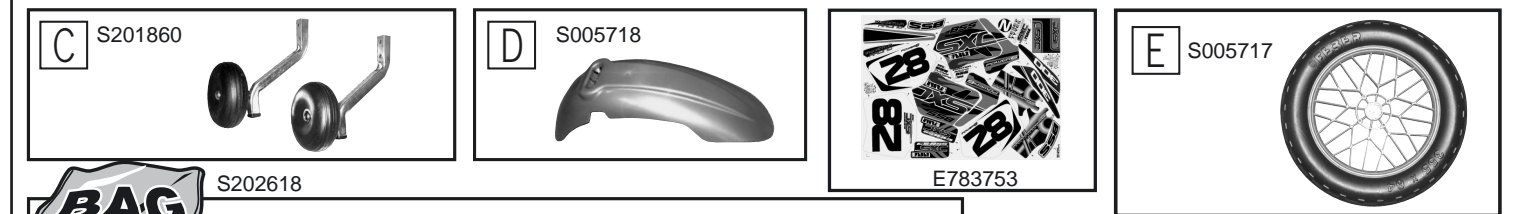
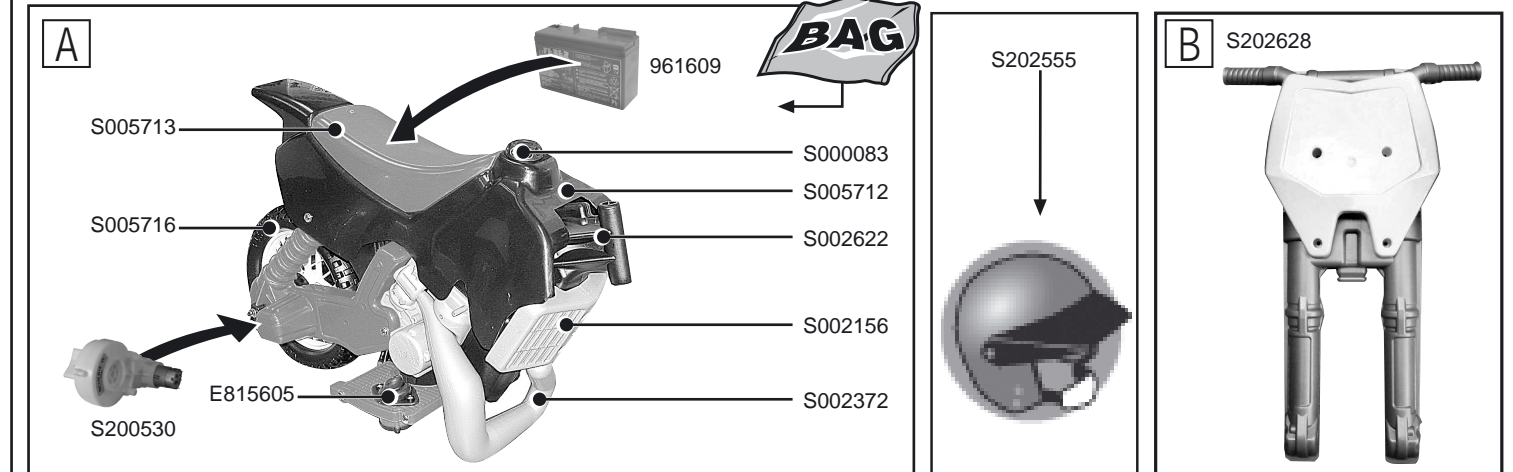

MONTAJE • ASSEMBLY • ASSEMBLAGE • BEDIENUNGSANLEITUNG • MONTAGE • MONTAGEM • MONTAGGIO

•REALIZAR POR UN ADULTO. SIGA ESTRUCTAMENTE LA SECUENCIA DE MONTAJE. ASEGÚRESE DE QUE TODOS TORNILLO, TUERCAS Y DEMÁS COMPONENTES, ESTÁN AJUSTADOS Y BIEN FIJADOS. EN CASO CONTRARIO PUEDE SER PELIGROSO PARA EL NIÑO.

•THIS SHOULD BE DONE BY AN ADULT. FOLLOW THE ASSEMBLY INSTRUCTIONS IN THE CORRECT SEQUENCE. MAKE SURE THAT ALL THE SCREWS, WASHERS, NUTS AND OTHER COMPONENTS ARE ADJUSTED AND SECURELY FIXED. IT COULD BE DANGEROUS FOR CHILDREN IF THIS IS NOT DONE.

•A RÉALISER PAR UN ADULTE. SUIVRE À LA LETTRE LE PROCESSUS DE MONTAGE. ASSUREZ-VOUS QUE CHAQUE VIS OU BOULON, RONDELLE, ÉCROU ET AUTRES COMPOSANTS SONT CORRECTEMENT AJUSTÉS ET FIXÉS. SI TEL N'ÉTAIT PAS LE CAS DANS LE CAS CONTRAIRE CELA POURRAIT S'AVÉRER DANGEREUX POUR L'ENFANT

•DIES IST VON EINEM ERWACHSENEN AUSZUFÜHREN. VERGEWISSERN SIE SICH, DASS ALLE SCHRAUBEN, UNTERLEGSCHIEBEN, MUTTERN UND WEITEREN ELEMENTE ANGEPAST UND FEST ANGEZOGEN SIND. DAS GEGENTEIL KANN FÜR DAS KIND SCHÄDLICH SEIN.

•UIT TE VOEREN DOOR EEN VOLWASSENE. VOLG DE MONTAGEVOLGORDE STRIKT OP. ZORG DAT ALLE SCHROEVEN, RINGEN, MOEREN EN OVERIGE ONDERDELEN AFGESTELD EN STEVIG BEVESTIGD ZIJN. ZO NIET KAN DIT GEVAAR OPLEVEREN VOOR HET KIND

•A REALIZAR POR UM ADULTO. SIGA ESTRITAMENTE A SEQUÊNCIA DE MONTAGEM. VERIFIQUE SE TODOS OS PARAFUSOS, ANILHAS, PORCAS E O RESTANTES COMPONENTES ESTÃO AJUSTADOS E BEM FIXADOS. CASO CONTRÁRIO, TORNAR-SE À PERIGOSO PARA AS CRIANÇAS.

•DEVE REALIZZARLO UN ADULTO. SEGUA STRETTAMENTE LA SEQUENZA DI MONTAGGIO. ASSICURARSI CHE TUTTE LE VITI, RONDELLE, DADI E TUTTI I COMPONENTI SIANO ASSEMBLATI E BEN FISSATI. IN CASO CONTRARIO PUO RISULTARE PERICOLOSO PER IL BAMBINO.



1

- Herramienta no incluida.
- The tool is not included.
- L'outil n'est pas inclus.
- Werkzeug nicht inbegriffen.
- Her werktuig is niet inbegrepen.
- A ferramenta não é incluída.
- L'attrezzo non è incluso.

- Herramienta incluida.
- The tool is included.
- L'outil est inclus.
- Werkzeug inbegriffen.
- Het werktuig is omvat.
- A ferramenta é incluída.
- L'attrezzo è incluso.

2

- Herramienta no incluida.
- The tool is not included.
- L'outil n'est pas inclus.
- Werkzeug nicht inbegriffen.
- Her werktuig is niet inbegrepen.
- A ferramenta não é incluída.
- L'attrezzo non è incluso.

3

4

5

6

7

8

9

CLICK!!

- Herramienta no incluida.
- The tool is not included.
- L'outil n'est pas inclus.
- Werkzeug nicht inbegriffen.
- Her werktuig is niet inbegrepen.
- A ferramenta não é incluída.
- L'attrezzo non è incluso.

MONTAJE ESTABICICLOS • STABILIZERS ASSEMBLY • ASSEMBLAGE STABILISATEURS • STÜTZRÄDER BEDIENUNGSANLEITUNG • ZIJWIELTJES MONTAGE • MONTAGEM RODINHAS ESTABILIZADORAS • MONTAGGIO STABILIZZATORI

2x

NUMERO DE OPERACIONES
NUMBER OF WORKING STEPS
NUMBER D'ÉTAPES DE TRAVAIL
ANZAHL DER ARBEITSGÄNGE
HET AANTAL DER BOUWHANDELINGEN
NUMERO DE OPERAÇÕES
NUMERO DI PASSAGGI

• CONEXIÓN DE LAS CLAVIJAS • CONNECTION OF PINS • BRANCHEMENT AUX BORNES • ANSCHLUSS DER STÖPSEL • AANSLUITING VAN DE OPLAADCONTACTEN • LIGAÇÃO DAS FICHAS • CONNESSIONE CON LE SPINE

CLICK!!

- REALIZAR POR UN ADULTO
- THIS SHOULD BE DONE BY AN ADULT
- A RÉALISER PAR UN ADULTE
- DIES IST VON EINEM ERWACHSENEN AUSZUFÜHREN
- UIT TE VOEREN DOOR EEN VOLWASSENE
- A REALIZAR POR UM ADULTO
- DEVE REALIZZARLO UN ADULTO